

Aluminium Mini Mill



**Voest Alpine
Industrieanlagenbau GmbH
and Hazelett Strip - Casting
Corporation join their forces
to promote an Aluminium Mini
Mill for the production of up
to 300.000 tonnes per year
of continuously cast and hot
rolled aluminium strip down
to a thickness of 1 mm.**

Aluminium Mini Mills 30,000 - 300,000 tonnes per year

Process Equipment

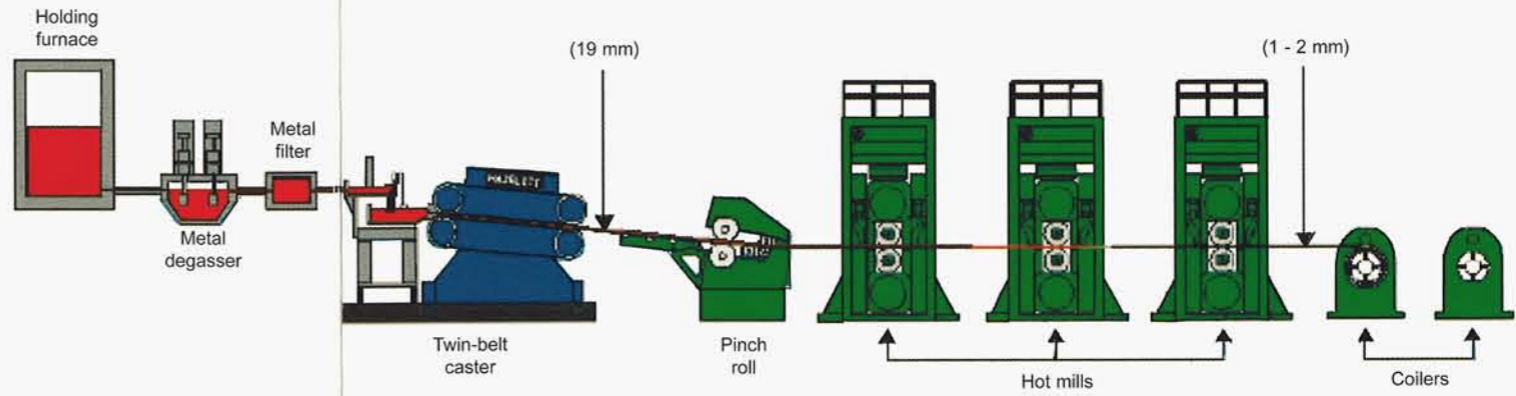

Twin Belt Caster

Fully moving mold

• Casting thickness	14 mm - 22 mm
• Casting widths to	2.300 mm
• Casting speed	6 m/min. - 9 m/min
• Casting rate	27 tonnes/meter width/hour



Hot Rolling Mill

Material

• Strip width	2.300 mm
• Entry thickness	19 mm
• Exit thickness	1 mm
• Coil weight	28.000 Kg max

Mill

• Two or three 4-Hi stands	
• Roll dimensions	730/1.600 x 2.500 mm
• Rolling load	5.500 tons
• Rolling Speed	170 m/min max
• Main motor power	3.000 kW

CC and Hot Tandem Mill

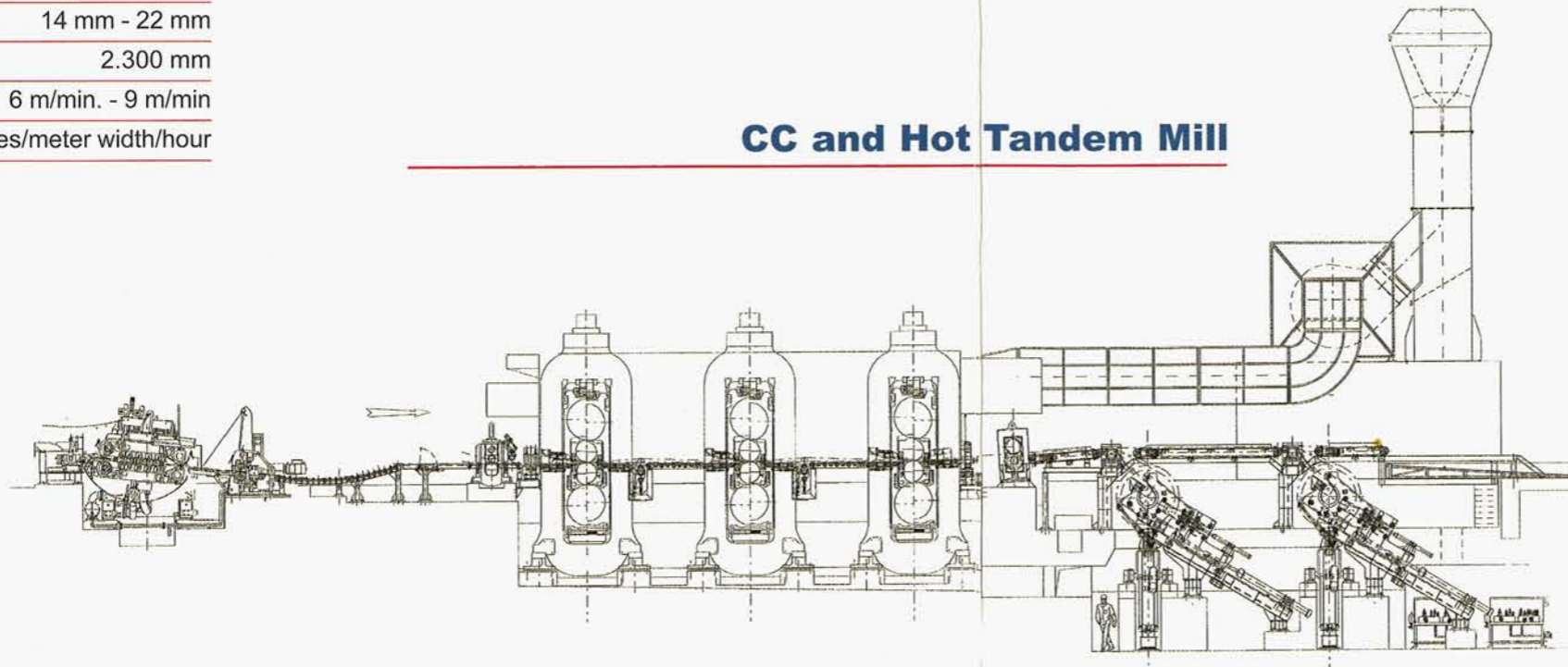

Products

The Mini Mill is able to produce a large range of products:

Alloy Commercial End Products

- | | |
|------------|---|
| 1050, 1100 | fin stock, heavy foil, lithographic plates, impact extrusions |
| 1200, 1350 | converter foil, cookware, electrical conductor |
| 3003, 3004 | architectural sheet, cookware, heavy foil |
| 3104, 3105 | flexible conduit, rain gutters, floor plate, bottle caps |
| 5005, 5042 | decorative sheet, beverage can tabs, welded tubing |
| 5052, 5349 | automotive stampings, truck trailers, utility sheet |
| 6061, 6111 | impact extrusions, tooling plate, forging slugs |
| 7072, 8111 | fin stock, cooking and serving trays, DDQ caps |

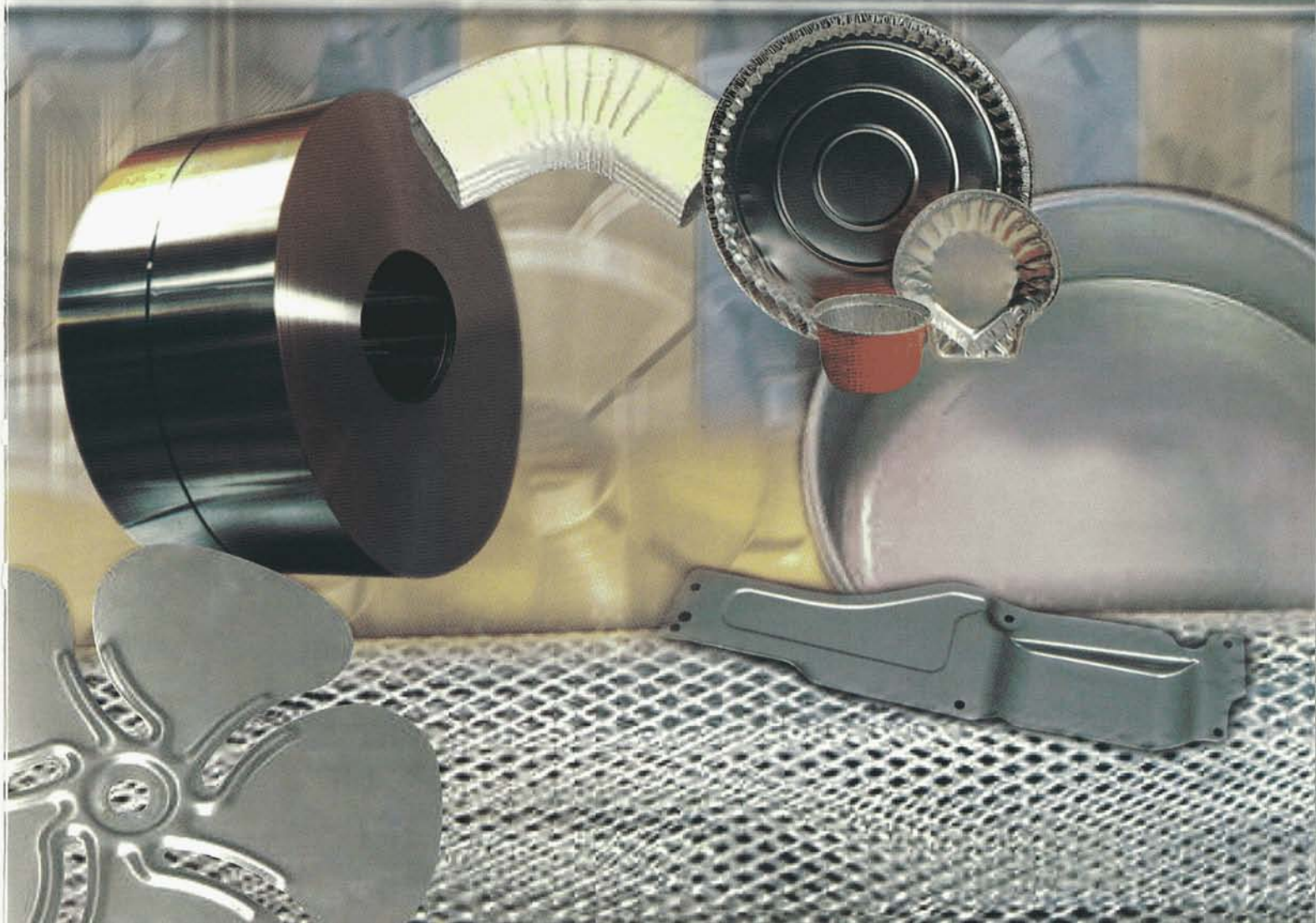

The striking benefits of the Mini Mill

The Mini Mill has been developed to meet the needs of a growing market for low cost production units. Compared to rival processes, it provides the following striking benefits :

- Short process route
- Reduced inventory
- Low conversion cost
- Low capital cost
- Hot band down to 1mm
- Stable process – Uniform quality
- Dynamic gauge and Alloy change capability
- Long runs – 10 days continuous

Strengths of VAI and Hazelett

VAI and Hazelett are ready to offer the Mini Mill as a package on a process turnkey basis :

- Process equipment
- Basic engineering
- Operational know how
- Training

By combining the following strengths

- Know how for producing aluminium strip
- Know how for designing and manufacturing advanced twin belt strip casters
- Know how for designing and manufacturing advanced rolling mills for aluminium flat products
- Market leading process automation capability
- Extensive ongoing research and development leading to continuous improvement of the process solution.

The Partners

Voest Alpine Industrieanlagenbau engineers and manufactures process equipment for the metal industry worldwide. VAI supplies innovative products answering today's customers needs ranging from aluminium rolling mills to complete process turnkey projects.

Hazelett Strip-Casting Co. engineers and manufactures continuous casting installations for flat and long non-ferrous products. Hazelett is the pioneer and world leader in twin belt casting.



VAI VOEST-ALPINE INDUSTRIES, INC.

Penn Center West, Building Four
Pittsburg, PA 15276
Tel.: (+1/412) 747-4600 - Fax: (+1/412) 747-4646
E-mail : vai@vaiipitt.vai.co.at



VAI UK VAI Industries (U.K.) Limited

Loewy House, 11 Enterprise Way, Aviation Park West
Bournemouth International Airport, Christchurch
Dorset BH23 6 EW - Great Britain
Tel.: (+44/0) 1202-331000 - Fax: (+44/0) 1202-581851
E-mail : Contact.rolling@vai.co.uk



VAI
COSIM

Paseo al Puerto, 12 - P.O. Box 41
48990 Guecho, Vizcaya - Spain
Tel.: (+34/94) 489-0400 - Fax: (+34/94) 489-0401
E-mail: vai-cosim@vai.at



VAI VOEST-ALPINE
Industrieanlagenbau GmbH & Co

Strip Processing Technology
Turmstrasse 44, P.O. Box 4 - A-4031 Linz / Austria
Tel.: (+43/70) 6592-8638 - Fax: (+43/70) 6980-5064
E-mail: Contact.processing@linz.vai.co.at
VAI Homepage: www.vai.at



VAI
GLECIM

Le Polyèdre, 53, rue des Trois Fontanot
92024 Nanterre Cedex - France
Tel.: (+33/1) 4696-7600 - Fax: (+33/1) 4696-7601
E-mail: andree.bodel@vai.fr
51, rue Sibert, B.P. 154
42403 Saint Chamond Cedex - France
Tel.: (+33/4) 7729-8056 - Fax: (+33/4) 7729-8385
E-mail: thierry.malard@vai.fr

HAZELETT

HAZELETT STRIP-CASTING CORPORATION

P.O. Box 600 - 135 Lakeshore Drive
Colchester, Vermont, USA 05446
Tel.: (802) 863-6376
Fax: (802) 863-1523
E-mail: sales@hazelett.com
Web site : www.hazelett.com